

KENWOOD

COMPACT Hi-Fi COMPONENT SYSTEM

K-525

INSTRUCTION MANUAL

Kenwood Corporation



**Declaration of Conformity with regard to the EMC Directive
2004/108/EC**

Manufacturer:

Kenwood Corporation
2967-3 Ishikawa-machi, Hachioji-shi, Tokyo, 192-8525 Japan

EU Representative's:

Kenwood Electronics Europe BV
Amsterdamseweg 37, 1422 AC UITHOORN, The Netherlands



Contents

Read the pages marked  carefully to ensure safe operation.

Before applying power	4
Safety precautions.....	4
IMPORTANT SAFETY INSTRUCTIONS	4

Read Before Use

Accessories	7
Preparation of remote control	7
Installation	8
Connections	9
Component names and functions.....	12

Playing music

Basic Operation.....	16
Playing a CD or audio file disc.....	18
Playback.....	18
Folder play mode.....	18
Program playback.....	20
Playback of Digital Audio Player.....	21
Playback.....	21
Playing an iPod/iPhone	22
Playback.....	22
Playing a USB device	24
Playback.....	24
Folder play mode	24
Program playback.....	26
Playing an external component	27
Playing an external component.....	27
Adjusting the input level (INPUT LEVEL).....	27
Listening to Radio Broadcasting.....	28
Listening to Radio Broadcasting.....	28
Presetting stations automatically (AUTO MEMORY).....	29
Presetting stations manually (Manual Preset).....	30
Radio Data System.....	30
PS (Program Service Name) Display.....	30
Searching for a desired program type (PTY search).....	31

Creating the desired sound setting

Sound Adjustments	32
Enhancing the bass tone (D-BASS).....	32
Adjusting the tone or playing surround audio (TONE).....	32
Resetting the adjusted sound to the original sound (FLAT).....	33

Advanced operations

System Setup.....	34
Adjusting the Time (TIME ADJUST).....	34
Setting the Sleep Timer (SLEEP).....	35
Setting the program timer (TIMER SET).....	36
Setting the display saver (DISP. SAVER).....	38
Setting Auto Power Save (A.P.S. SET).....	38
Adjusting the recording output level (Rec Out LEVEL).....	39
Setting the brightness of the display (DIMMER).....	39
Switching the Display Information	40

Maintenance

Additional Information	41
Media Usable With This System.....	41
Caution for Disc Writing.....	41
Playable audio files.....	42
Handling of CD.....	44
Handling of D.AUDIO.....	44
Handling of iPod.....	44
Handling of USB device.....	45
Caution for Transport or Movement.....	45
Memory Backup.....	45
Troubleshooting	46
Amplifier/Speaker Section.....	46
Tuner Section.....	46
USB /iPod/iPhone Section.....	46
CD Section.....	47
Component connected to D.AUDIO IN connector.....	47
Remote Control Unit.....	47
Resetting the system.....	47
Message List	48
Glossary	49
Care and Storage	50
Specifications	51

Read Before Use

Playing music

Creating the desired sound setting

Advanced operations

Maintenance

Before applying power





⚠ Caution : Read this page carefully to ensure safe operation.

Units are designed for operation as follows.

Australia AC 240 V only
Europe AC 230 V only

Safety precautions

WARNING : TO PREVENT FIRE OR ELECTRIC SHOCK, DO NOT EXPOSE THIS APPLIANCE TO RAIN OR MOISTURE.

	CAUTION RISK OF ELECTRIC SHOCK DO NOT OPEN	
CAUTION: TO REDUCE THE RISK OF ELECTRIC SHOCK, DO NOT REMOVE COVER (OR BACK). NO USER-SERVICEABLE PARTS INSIDE. REFER SERVICING TO QUALIFIED SERVICE PERSONNEL.		
	THE LIGHTNING FLASH WITH ARROWHEAD SYMBOL, WITHIN AN EQUILATERAL TRIANGLE, IS INTENDED TO ALERT THE USER TO THE PRESENCE OF UNINSULATED "DANGEROUS VOLTAGE" WITHIN THE PRODUCT'S ENCLOSURE THAT MAY BE OF SUFFICIENT MAGNITUDE TO CONSTITUTE A RISK OF ELECTRIC SHOCK TO PERSONS.	
	THE EXCLAMATION POINT WITHIN AN EQUILATERAL TRIANGLE IS INTENDED TO ALERT THE USER TO THE PRESENCE OF IMPORTANT OPERATING AND MAINTENANCE (SERVICING) INSTRUCTIONS IN THE LITERATURE ACCOMPANYING THE APPLIANCE.	

The marking of products using lasers



The marking this product has been classified as Class 1. It means that there is no danger of hazardous radiation outside the product.

Location: Back panel

IMPORTANT SAFETY INSTRUCTIONS

⚠ Caution : Read this page carefully to ensure safe operation.

Read These Instructions

– All the safety and operating instructions should be read before the product is operated.

Keep These Instructions

– The safety and operating instructions should be retained for future reference.

Heed All Warnings

– All warnings on the product and in the operating instructions should be adhered to.

Follow All Instructions

– All operating and use instructions should be followed.

1. Clean only with dry cloth

– Unplug this product from the wall outlet before cleaning. Do not use liquid cleaners or aerosol cleaners. Use a damp cloth for cleaning.

2. Attachments

– Only use attachments/accessories specified by the manufacturer.

3. Do not use this apparatus near water

– This product shall not be exposed to dripping and splashing – for example, near a bath tub, wash bowl, kitchen sink, or laundry tub; in a wet basement; or near a swimming pool; and the like. Do not place an object containing liquid, such as a flower vase, on the appliance.

4. Accessories

– Use only with the cart, stand, tripod, bracket, or table specified by the manufacturer, or sold with the apparatus. When a cart is used, use caution when moving the cart/apparatus combination to avoid injury from tip-over.



5. Ventilation

– Slots and openings in the cabinet are provided for ventilation and to ensure reliable operation of the product and to protect it from overheating. Do not block any ventilation openings. Install in accordance with the manufacturer's instructions. The openings should never be blocked by placing the product on a bed, sofa, rug, or other similar surface. This product should not be placed in a built-in installation such as a bookcase or rack unless proper ventilation is provided or the manufacturer's instructions have been adhered to.

6. Power Sources

– This product should be operated only from the type of power source indicated on the product. If you are not sure of the type of power supply to your home, consult your product dealer or local power company.

7. CAUTION – Polarization

– Do not defeat the safety purpose of the polarized or grounding-type plug. A polarized plug has two blades with one wider than the other. A grounding type plug has two blades and a third grounding prong. The wide blade or the third prong are provided for your safety. If the provided plug does not fit into your outlet, consult an electrician for replacement of the obsolete outlet.

8. Power Cord Protection

– Protect the power cord from being walked on or pinched particularly at plugs, convenience receptacles, and the point where they exit from the apparatus.

9. Lightning

– Unplug this apparatus during lightning storms or when unused for long periods of time.

10. Overloading

– Do not overload wall outlets, extension cords, or integral convenience receptacles as this can result in a risk of fire or electric shock.

11. Object and Liquid Entry

– Never push objects of any kind into this product through openings as they may touch dangerous voltage points or short-out parts that could result in a fire or electric shock. Never spill liquid of any kind on the product.

12. Servicing

– Do not attempt to service this product yourself as opening or removing covers may expose you to dangerous voltage or other hazards. Refer all servicing to qualified service personnel.

13. Damage Requiring Service

– Refer all servicing to qualified service personnel. Servicing is required when the apparatus has been damaged in any way, such as power-supply cord or plug is damaged, liquid has been spilled or objects have fallen into the apparatus, the apparatus has been exposed to rain or moisture, does not operate normally, or has been dropped.

14. Replacement Parts

– When replacement parts are required, be sure the service technician has used replacement parts specified by the manufacturer or have the same characteristics as the original part. Unauthorized substitutions may result in fire, electric shock, or other hazards.

15. Safety Check

– Upon completion of any service or repairs to this product, ask the service technician to perform safety checks to determine that the product is in proper operating condition.

16. Wall or Ceiling Mounting

– This product should be mounted to a wall or ceiling only as recommended by the manufacturer.

17. Heat

– Do not install near any heat sources such as radiators, heat registers, stoves, or other apparatus (including amplifiers) that produce heat. Do not place a flaming object, such as a candle or lantern, or near the product.

18. Power Lines

– An outside antenna system should not be located in the vicinity of overhead power lines or other electric light or power circuits, or where it can fall into such power lines or circuits. When installing an outside antenna system, extreme care should be taken to keep from touching such power lines or circuits as contact with them might be fatal.

Notes:

Item 7 is not required except for grounded or polarized equipment.

Accessories

Accessories

Remote control unit
(RC-F0513E x 1)

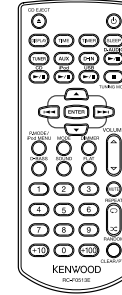

Remote control batteries
(LR03 (AAA) x 2)

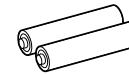

FM indoor antenna
(x 1)

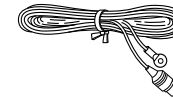

Power cords (2 types)



For Europe

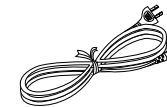

For Australia

Preparation of remote control

Loading batteries in the remote control unit

1 Remove the battery cover.

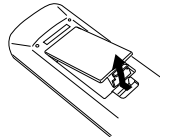

2 Insert the provided AAA-size batteries.

- Insert batteries with correct polarity.

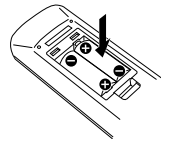

3 Close the battery cover.

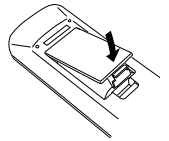

- The provided batteries are intended for use in operation check and their service life may be shorter than usual.
- When replacing batteries, be always sure to replace both of the two batteries together.

CAUTION

Do not leave the battery near fire or under direct sunlight. A fire, explosion or excessive heat generation may result.

Information on Disposal of Old Electrical and Electronic Equipment and Batteries (applicable for EU countries that have adopted separate waste collection systems)



Products and batteries with the symbol (crossed-out wheeled bin) cannot be disposed as household waste.



Old electrical and electronic equipment and batteries should be recycled at a facility capable of handling these items and their waste by products.



Contact your local authority for details in locating a recycle facility nearest to you. Proper recycling and waste disposal will help conserve resources whilst preventing detrimental effects on our health and the environment.

Pb

Notice: The sign "Pb" below the symbol for batteries indicates that this battery contains lead.

Installation

Installation precautions

- Always install the system on a level, stable surface. When installing on a stand or tabletop, be sure to confirm the strength of the stand.
- The magnetism from the speakers may cause color irregularities on a nearby TV or PC screen. Always install the speakers at a distance from a TV or PC.

CAUTION

Observe the following cautions when installing the system. Insufficient heat radiation may build up internal heat and cause a malfunction or fire hazard.

- Do not place an object that may hinder heat radiation on the system.
- Do not install the system on the back, on the side or upside down.
- Do not place a cloth on the system or place it on a carpet or cushion.
- Do not use the system in a poorly ventilated place.
- Leave the spaces specified below around the cabinets of the main unit.
Top: 50 cm or more Side: 10 cm or more Rear: 10 cm or more

Install the system so that the power outlet is easily accessible from the user, and unplug the power cord from the power outlet immediately in case of a trouble.

Note that the power supply to the system is not shut down completely by simply setting the power button to OFF. To shut down the power supply completely, it is required to unplug the power cord.

Malfunction of the system

If the system does not function properly or the display shows erroneous information even when the connections are made correctly, reset the system (page 47).

Connections

Basic connections

Caution for connection

Do not plug the power cord into the power outlet until all other connections are completed. Before unplugging a connected cord or cable, be sure to switch the system OFF and unplug the power cord from the power outlet in advance.

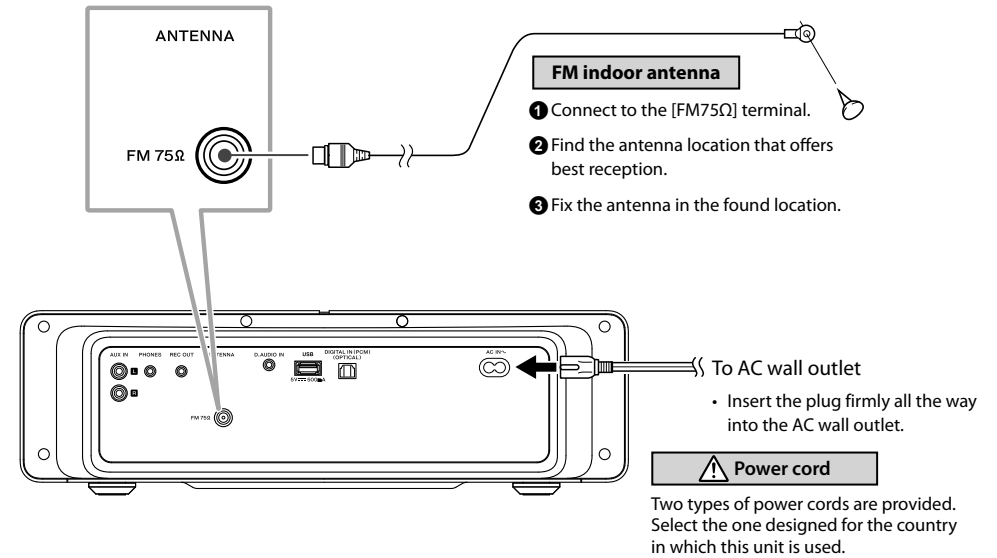

Connecting the FM indoor antenna

The provided FM antenna is a simplified one for indoor use. To receive FM stations stably, it is recommended to use an outdoor antenna (commercially available). Remove the simplified antenna before connecting the outdoor antenna.

Caution for outdoor antenna installation

Since antenna installation necessitates skill and experience, always consult your dealer before installation. The antenna should be placed at a distance from the power distribution wires. Otherwise, an electric shock accident may occur if the antenna falls down.

Connections

Connecting Associated Products (Commercially Available)

- Before connecting associated system products, be sure to read their instruction manuals.
- Connect every connection cord firmly. Incomplete insertion may cause loss of audio output or generation of noise.

Caution for connection

Set the main unit in the standby mode before connecting any associated product to it and do not set the power button to ON until all connections are completed. Before unplugging a connected cord or cable, be sure to set the power button to OFF and unplug the power cord from the power outlet in advance.

iPod/iPhone (iPod/iPhone applied part)

Attach the Dock adapter supplied with the iPod/iPhone to the system. Open the cover on the main unit, and then push down the Dock adapter into the unit with its slit facing toward the unit until it clicks.

- You cannot attach an iPod/iPhone to the system if it is in a cover, case, or with other accessories. Always remove it.
- Connecting an iPod/iPhone to the system without using the Dock adapter may deteriorate or damage the connector. Always use the Dock adapter.
- Keep the iPod/iPhone on a straight position while connecting/disconnecting it.
- Once the iPod/iPhone is connected, it can be charged. (without select USB source)

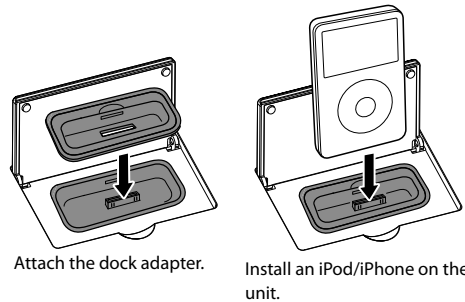

To disconnect the dock adapter...

Insert the blade of a flat-blade screwdriver into the slit on the dock adapter and lift it.

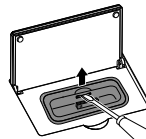

USB (USB device connector)

Connect a USB flash memory or a digital audio player with USB mass storage class compatibility to the [USB] terminal on the rear of this unit.

- With certain models, it takes a certain period before the connection is recognized.
- Certain models display the USB connection mode selection menu. In this case, select the "Storage" mode.
- The USB device cannot be recognized via a USB hub, etc.
- Once the USB device (charging type) is connected, it can be charged. (Select USB source only)

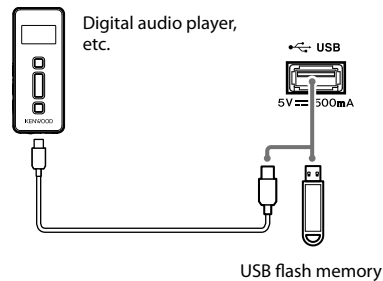

D.AUDIO IN (D.AUDIO input connector)

Connect a digital audio player to the [D.AUDIO IN] terminal on the rear of this unit.

- When a Kenwood digital audio player with digital audio link compatibility is connected using the dedicated cable (separately available), the player can be controlled from this system or its remote control unit.
- A digital audio player other than above can be connected using a stereo mini plug cable (commercially available).

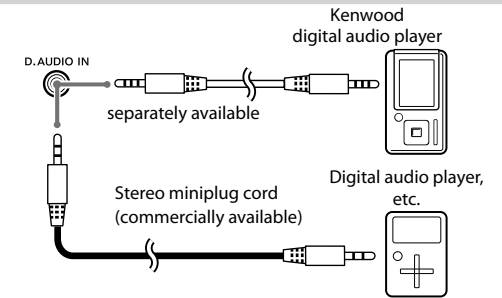

REC OUT (Recording output connector)

Connect a Kenwood digital audio player/recorder with direct encoding function to the [REC OUT] terminal on the rear of this unit.

- The [REC OUT] connector outputs analog audio signals.
- Note that, if the input selector is set to [iPod], the audio output from the iPhone/iPod is not output at the [REC OUT] terminals.

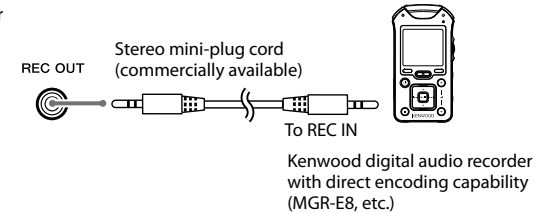

AUX IN (Auxiliary input connector)

Connect the audio output of the VCR, etc. to the [AUX IN] terminals on the rear of this unit.

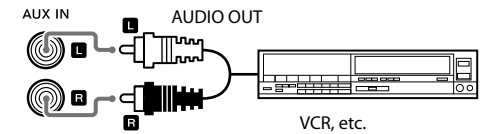

DIGITAL IN (Digital audio input connector)

Connect the optical digital output of a digital tuner, etc. to the [DIGITAL IN] connector on the rear of this unit.

- Set the digital audio setting of the connected component to "PCM".

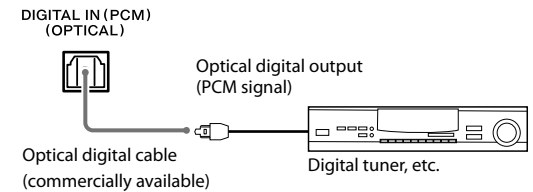

PHONES (Headphones connector)

Connect headphones with a stereo mini-plug to the [PHONES] connector on the rear of this unit.

Connecting headphones mutes the sound from the speakers.

- When the input selector is set to [iPod], the audio output from the iPhone/iPod is not output from headphones even when these are connected to the PHONES connector. When using the iPhone/iPod, listen to the music through the speakers without using headphones.

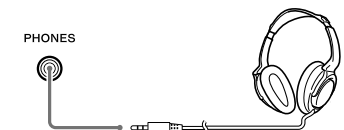

CAUTION

A warning that excessive sound pressure from earphones and headphones can cause hearing loss.

Component names and functions

Main unit

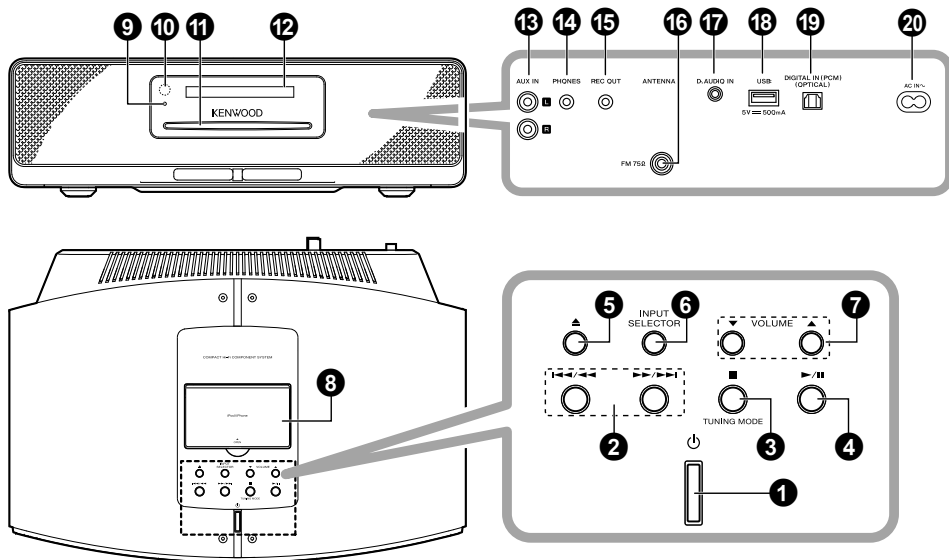

1 (Power)

- Press to switch the power ON/OFF (standby).

2

- Press to skip the music.
- Press and hold to fast forward or fast backward the music.
- During radio listening, press to select a station.

3 (STOP)/TUNING MODE

- Press to stop playback of CD/USB/D.AUDIO.
- During radio listening, pressing the button switches the tuning mode between auto and manual.

4 /

- Press to play the CD/USB/iPod/iPhone/D.AUDIO or let it pause.

5 CD EJECT

- Eject the disc.

6 INPUT SELECTOR

- Press to switch the input sources in order of [TUNER] → [CD] → [iPod] → [USB] → [D.AUDIO] → [DIGITAL IN] → [AUX].

7 VOLUME / (Volume control)

- Press to control the volume level. Pressing increases the volume level and pressing decreases it.

8 iPod/iPhone applied part

- Open the cover before attaching an iPod/iPhone.

9 STANDBY/TIMER indicator

- Red: Normal standby mode.
- Orange: Timer standby mode

10 Remote control sensor

11 Disc slot

12 Display

13 AUX IN (Auxiliary input connector)

14 PHONES (Headphones connector)

- Connect headphones equipped with a stereo mini-plug.

15 REC OUT (Recording output connector)

16 ANTENNA terminal

- Connect the provided FM indoor antenna.

17 D.AUDIO IN (D.AUDIO input connector)

18 USB (USB device connector)

19 DIGITAL IN (Digital audio input connector)

20 AC IN (Power input connector)

- Connect the unit to a mains outlet using the provided power cord.

Display

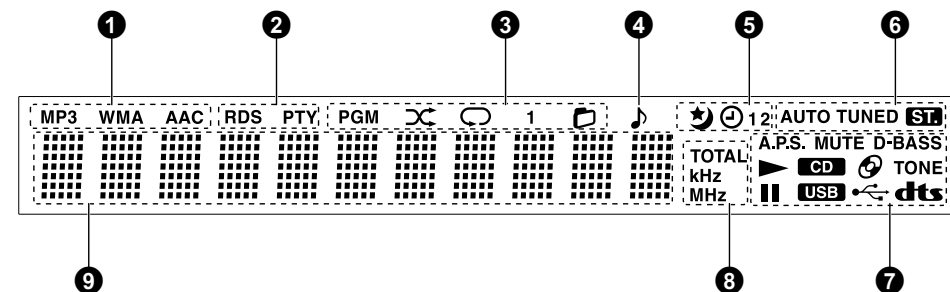

1 Light to indicate the type of the audio file being played (MP3/WMA/AAC)

2 Light when an Radio data system station is tuned or the PTY mode is selected.

RDS : Lights when an Radio data system station is tuned.

PTY : Lights when PTY is selected.

3 Lights when a playback mode is set.

PGM : Program play mode

: Random play mode.

1 : Repeat play mode (1 indicates the single track/file repeat).

: Folder play mode.

4 Lights when music is played or in pause.

5 Light when the sleep/program timer is set.

: Sleep timer

1 : Program timer 1

2 : Program timer 2

12 : Program timer 1/2

6 Indicate the radio tuning conditions.

AUTO : Lights in auto tuning mode. Does not light in manual tuning mode.

TUNED : Lights when a station is tuned.

ST. : Lights when stereo broadcasting is tuned.

7 Indicate the sound setups and CD/USB device status.

A.P.S. : Lights when Auto Power Save is set.

MUTE : Flashes during muting.

D-BASS : Lights when D-BASS is set.

TONE : Lights when TONE is set.

: Lights during playback.

: Lights during pause.

: Lights when the CD input source is selected.

: Lights when the USB input source is selected.

: Lights when a disc is inserted.

: Lights when a USB device is connected.

: Lights when DTS Surround Sensation is set.

8 Light when the time indication or radio turning frequency is displayed.

TOTAL : Lights to indicate the elapse time and remaining time of the disc during CD playback.

kHz : Lights when the sampling frequency is displayed.

MHz : Shows the FM tuning frequency.

9 Character display

The display illustrations shown in this manual may differ from actual display.

Standby mode

When the [STANDBY/TIMER] indicator is lit, a small amount of power is supplied to the system to operate the microcomputer. This status is referred to as the standby mode. In this state, the system can be switched OFF from the remote control unit.

Remote Control Unit

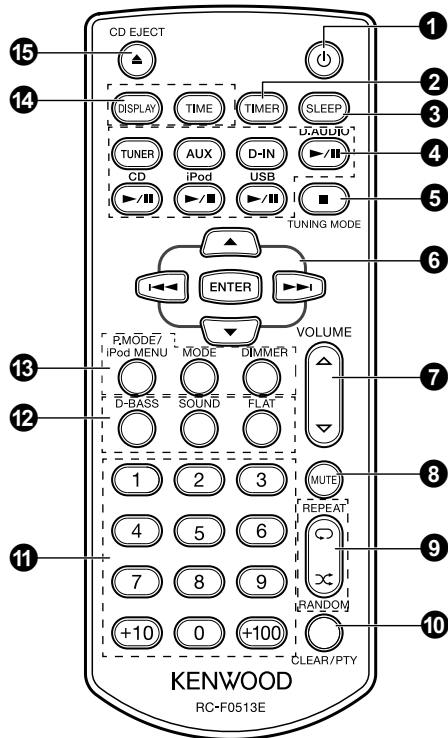

- 1** **POWER**
 - Press to switch the power ON/OFF (standby).
- 2** **TIMER**
 - Press to switch the set program(s) ON/OFF.
- 3** **SLEEP**
 - Press to set the sleep timer.
- 4** **Press to select the input source.**
 - TUNER(Radio)**
 - Press to select the TUNER source.
 - AUX**
 - Press to select the AUX input.
 - D-IN (DIGITAL IN)**
 - Press to select the DIGITAL IN input.

- D.AUDIO**
 - Press to play the D.AUDIO component or let it pause.
- CD**
 - Press to play the CD or let it pause.
- iPod**
 - Press to play the iPod/iPhone or let it pause.
- USB**
 - Press to play the USB device or let it pause.
- 5** **(STOP)/TUNING MODE**
 - Press to stop playback of CD/USB/D.AUDIO.
 - During radio listening, pressing the button switches the tuning mode between auto and manual.
 - Press during a setup to stop it in the middle.
- 6** **Press to select the music/radio station or to set an item.**
 - ▲/▼
 - Press to select a folder.
 - Press to enter the selected iPod/iPhone menu item.
 - ◀/▶
 - Press to skip the music.
 - Press and hold to fast forward or fast backward the music.
 - During radio listening, press to select a station.
 - Press to select the setup items.
- ENTER**
 - Press to enter the selected item.
- 7** **VOLUME ▲/▼ (Volume control)**
 - Press to control the volume level. Pressing ▲ increases the volume level and pressing ▼ decreases it.
- 8** **MUTE**
 - Press to mute the sound temporarily.
- 9** **Play mode selectors**
 - RANDOM**
 - Plays music in a random order.
 - REPEAT**
 - Repeats playback.
- 10** **CLEAR/PTY**
 - Press to clear a program.
 - Performs PTY search.

- 11** **Numeric buttons**
 - Press to select the music or radio station.
- 12** **Sound setting selectors**
 - D-BASS**
 - Enhances the low frequencies.
 - SOUND**
 - Adjusts the sound.
 - Sets DTS Surround Sensation.
 - FLAT**
 - Resets the adjusted sound to the original sound.
- 13** **Selects the play mode or to set an item**
 - P.MODE/iPod MENU**
 - Selects the play mode.
 - Call the iPod/iPhone menu display.
 - MODE**
 - Press to start the setup of this unit.
 - DIMMER**
 - Sets the display brightness.
- 14** **Display mode selectors**
 - DISPLAY**
 - Press to switch the information shown on the display.
 - TIME DISPLAY**
 - Switches the displayed time information.
- 15** **CD EJECT**
 - Ejects the disc.

The buttons having the same names as the buttons on the main unit function in the same way as the main unit buttons with the same times.

Operation

Plug the power cord of the system to a power outlet and press [POWER] on the remote control unit to turn the system ON. After the system is switched ON, press the desired operation button. Use the remote control unit by pointing it to the remote sensor on the main unit.

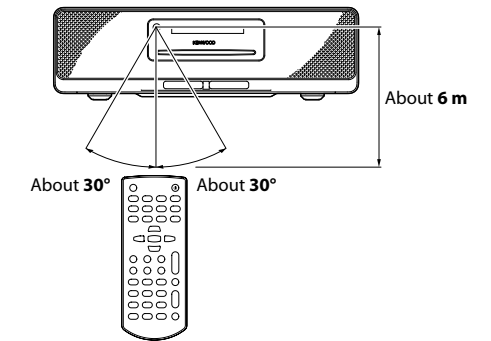

The system may malfunction if the remote control sensor is exposed to direct sunlight or the light of a fluorescent lamp with high frequency lighting system (inverter system, etc.). Change the system installation to prevent malfunction.



One touch operation function

The system incorporates the convenient one touch operation function. When the system is in standby mode, pressing any of input source button turns the system ON. Playback also starts if a button related to CD or USB, D.AUDIO, iPod and iPhone is pressed.

Resume function



After the music from a CD or USB pauses during playback, pressing [CD] or [USB] restarts the of the music from the beginning.

Basic Operation

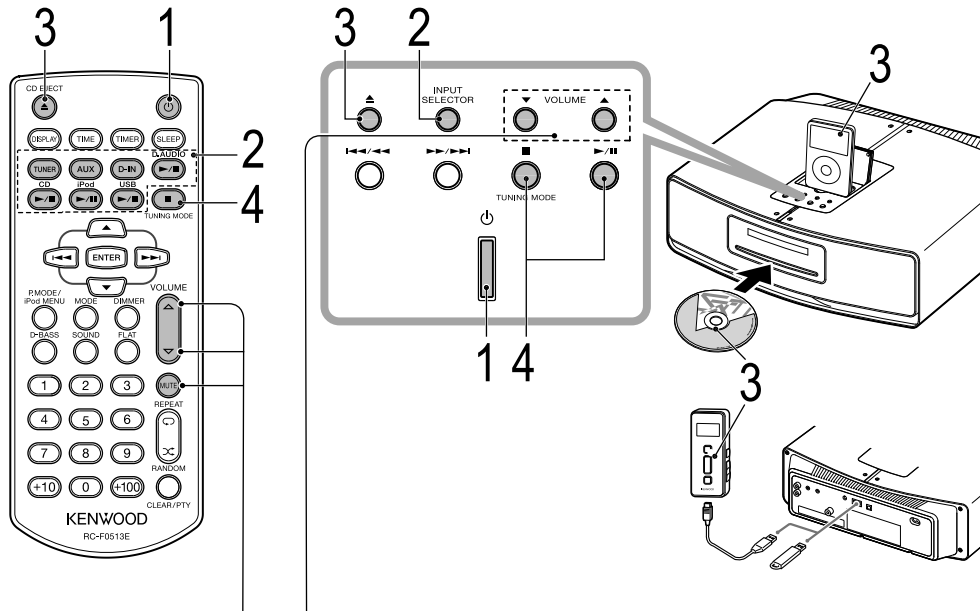
-  This symbol indicates an operation on the main unit. When it is marked, perform the operation by pressing the required button(s) on the main unit.
-  This symbol indicates an operation on the remote control unit. When it is marked, perform the operation by pressing the required button(s) on the remote control unit.
-  If both are marked, the operation is available either on the remote control unit or this unit.



Adjusting the volume

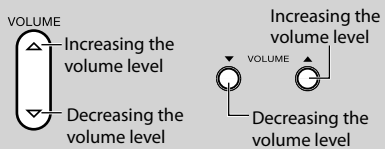

  Adjust using [VOLUME].



Adjust in the range from 0 to 40 (max.).

 Press and hold the button to vary the volume level at a high speed.

Muting the sound temporarily

  Press [MUTE].
"MUTE" blinks on the display.

To cancel muting...

Press [MUTE] again (this resumes the original volume) or adjust the volume.



1 Turn the system ON (OFF).

  Press [⏻].

- Pressing the play/pause [▶/||] button of the desired audio input source also turns the system ON (page 15, "One touch operation function").
- Pressing [⏻] while the system is ON switches it OFF (standby mode).

2 Select the audio source.

Press the play/pause button of the desired audio source.

  Press [TUNER]/ [AUX]/ [D-IN]/ [D.AUDIO▶/||]/ [CD▶/||]/ [iPod▶/||]/ [USB▶/||].

 Press [INPUT SELECTOR].



Press [INPUT SELECTOR] on main unit to switch the input source in order of [TUNER] → [CD] → [iPod] → [USB] → [D.AUDIO] → [DIGITAL IN] → [AUX].

With the CD/iPod inputs, loading a disc or iPod/iPhone in this unit selects the corresponding input source automatically.

3 Set the source to be played.

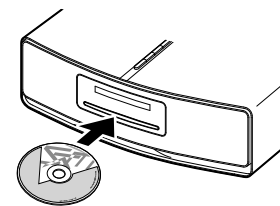
How to load a disc



Hold the disc with the label side up and insert it into the centre of the disc slot. "LOADING" is displayed and the input source is switched to CD . When the disc is loaded, "" lights and playback starts automatically.

To eject the disc...

Press CD EJECT[▲]. "EJECT" is displayed and the disc is ejected.

How to connect a USB device

Hold the device in the correct orientation and insert the connector all the way. When you select USB source, "READING" is displayed and the input source is switched to USB . "↔" lights.

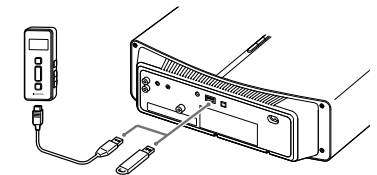

To remove the USB device...

After stopping, set the system to the standby mode and pull out the USB device.

How to install iPod/iPhone

Install iPod/iPhone on the unit. "READING" is displayed and the input source is switched to iPod and playback starts automatically.

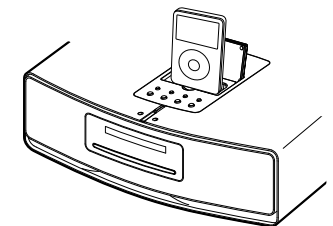



To remove the iPod/iPhone...

After stopping, set the system to the standby mode and pull out the iPod/iPhone.

4 Start playback.

Play the connected input source.

When you select USB source.

  Press [USB▶/||]/[▶/||].

To stop playback of CD/USB/D.AUDIO...

Press [■] during playback.

Playing a CD or audio file disc

A CD or a CD-ROM/CD-R/CD-RW containing audio files can be played as described below.

- For the playable files, see "Playable audio files" (page 42).

Playback

1 Load the disc and play it.

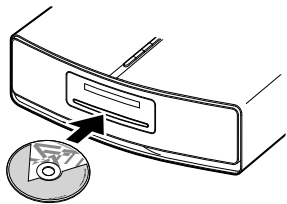

Hold the disc with the label side up and insert it into the centre of the disc slot. "LOADING" is displayed and the input source is switched to CD. When the disc is loaded, "CD" lights and playback starts automatically.

When a CD is played.



Display when an audio file is played.



The CD is played from the first track.

When a disc containing audio files is played, the folders and files are searched and playback is started with the file with the smallest file number.

- For the order of playback when there are multiple folders and/or audio files, see "Order of playback folders and audio files" (page 43).

- With a CD-TEXT compatible disc, character information including the track title and album title is displayed.

Folder play mode

Audio file disc only

The system can be set to a mode for playback per folder. In this mode, the system plays only the selected folder and stops after all of its files have been played.

- Select the CD source and enter stop mode.

1 Select " " (folder play mode).



Press [P.MODE].

Each press switches the playback mode.

lit	Folder play mode
PGM lit	Program play mode
Not lit	Normal play mode

Display when the folder play mode is selected.



2 Select a folder and play it.



Press [▲]/[▼].

Display when folder 5 is selected.



When a folder is selected, "FOLDER" is displayed and the selected folder starts to play automatically.

■ To cancel the folder play mode...

Stop playback and press [P.MODE] to select the normal play mode.

Button operations during playback/stop

To	Operation
Switch the display information	Press [DISPLAY] during playback or pause. Each press switches the displayed information (page 40).
Switch the time display information	Press [TIME DISPLAY]. Each press switches the displayed information (page 40).
Stop	Press [] during playback.
Pause	Press [CD ▶/]/[▶/] during playback. Press again to resume playback.
Select a track/ file	Press the [Numeric] button(s). Track/ file number selection methods: 7th track/ file → Press [7]. 12th track/ file → Press [+10], [2]. 103rd file → Press [+100], [3].
Folder selection (Audio files)	Press [▲]/[▼].
Fast forward/ fast backward	Press and hold [I◀◀]/[▶▶I]/[I◀◀◀]/[▶▶▶I] during playback.
Skip a track/ file	Press [▶▶I]/[▶▶▶I].
Return to previous track/ file	Press [I◀◀]/[I◀◀◀] successively twice or more.
Return to the beginning of current track/ file	Press [I◀◀]/[I◀◀◀] once.
Start random playback (Playing music in a random order)	Press [RANDOM]. Each press switches the selection. Random playback is set. Random playback is cancelled.
Start repeat playback (Playing music repeatedly)	Press [REPEAT]. Each press switches the selection. Repeat playback of a single track/ file. Repeat playback of all tracks/ files. Repeat playback is cancelled.

Playing a CD or audio file disc

Program playback

Music in a CD or audio file disc can be played in the order programmed by the user.

- Select the CD source and enter stop mode.

1 Select "PGM" (program play mode).

 Press [P.MODE].

Each press switches the playback mode.

CD operation

PGM lit

Program play mode

Not lit

Normal play mode

Audio file disc operation

lit

Folder play mode

PGM lit

Program play mode

Not lit

Normal play mode

Display when the program mode is selected for a CD.



2 Select a track/ file.

CD operation

 Select the track with [I◀◀]/[▶▶I] or [Numeric] buttons, and press [ENTER].

When the 7th track is selected as the first track of the program.



Audio file disc operation

 Select the folder with [I◀◀]/[▶▶I] or [Numeric] buttons, and press [ENTER].

Select an audio file with [I◀◀]/[▶▶I] or [Numeric] buttons, and press [ENTER].



Display when file 10 in folder 003 is programmed as the 1st file in the program.



If you committed a mistake in selection, press [CLEAR] on the remote control unit before pressing [ENTER] and restart selection.

- Up to 32 files can be programmed.

3 Start playback.

  Press [CD▶/||]/[▶/||].

■ To clear a track/ file from the program...

Stop playback and press [CLEAR] on the remote control unit. Each press clears the last track/ file in the current program.

■ To add a track/ file to the program after programming...

If playback is underway, stop it and perform steps 2 and after.

■ To cancel the program mode...

Stop playback and press [P.MODE] to select the normal play mode. The program is cleared at this time.

-  The set program is cleared when the input source is switched, the disc is ejected or the unit is switched OFF.

Playback of Digital Audio Player

Kenwood digital audio player can be connected to play audio files in it.

- For the Kenwood digital audio players models that can be connected to this unit, see "Handling of D.AUDIO" (page 44).

Playback

1 Connect the player.

Connect a Kenwood digital audio player to the [D.AUDIO IN] connector using an optional cable or adapter (page 11).

Also read the instruction manual for the connected component.

2 Select the "D.AUDIO" input.

 Press [D.AUDIO▶/||].

 Press [INPUT SELECTOR].













Display when the D.AUDIO input is selected.



3 Turn the connected player ON and start playing it.

-  While the player is connected to this system, the volume and tone settings on the player are defeated. If the input level from D.AUDIO seems to be higher or lower than other input sources when this unit is set at the same volume level, adjust the input level as described in "Adjusting the input level" (page 27).

Button operations during playback/stop

To	Operation
Stop	  Press [■] during playback.
Pause	  Press [D.AUDIO▶/] / [▶/] during playback. Press again to resume playback.
Skip a folder	 Press [▲]/[▼].
Fast forward/ fast backward	  Press and hold [I◀◀]/[▶▶I] / [I◀◀◀]/[▶▶▶▶] during playback.
Skip a file	  Press [▶▶▶]/[▶▶▶▶].
Return to previous file	  Press [I◀◀]/[I◀◀◀] successively twice or more.
Return to the beginning of current file	  Press [I◀◀]/[I◀◀◀] once.

- Some control operations may be unavailable depending on the connected player.

■ Dedicated cable/device for connection

When the Kenwood digital audio player is connected using the optional Kenwood digital audio player connection cable, the connected component can be controlled from this unit or the remote control unit.

For details on the connection and installation, refer to the instruction manual provided with the connection cable.

Playing an iPod/iPhone

This unit can play music stored in iPod/iPhone.

- For the iPod/iPhone models that can be connected to this unit, see "Usable iPod/iPhone models" (page 45).

Playback

1 Install an iPod/iPhone on the unit.

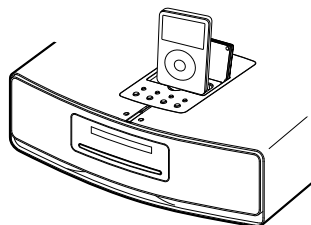

"READING" is displayed and the input source is switched to iPod and playback starts automatically.

Display when the iPod input is selected.



- iPod/iPhone cannot be connected together with accessories such as the cover or case. Be sure to remove the accessories before connecting.
- If iPod/iPhone is connected directly to this unit without using the dock adapter, the connector may be damaged. Be always sure to use the dock adapter (page 10).
- Keep the iPod/iPhone on a straight position while connecting/disconnecting it.
- Be sure to read the instruction manuals provided with your iPod/iPhone.
- Update the software of your iPod/iPhone to the latest version before use.

Button operations during playback/stop

To	Operation
Switch the display information	Press [DISPLY] during playback or pause. Each press switches the displayed information (page 40).
Call to iPod/iPhone menu display	Press [iPod MENU]. Call to iPod/iPhone menu display. Press to [▲]/[▼] enter the selected iPod/iPhone menu item.
Pause	Press [iPod ▶/]/[▶/] during playback. Press again to resume playback.
Select a file	Press [I◀◀◀]/[▶▶▶I].
Fast forward/fast backward	Press and hold [I◀◀◀]/[▶▶▶I]/[I◀◀◀◀◀◀]/[▶▶▶▶▶I] during playback.
Skip a file	Press [▶▶▶I]/[▶▶▶▶▶I].
Return to previous file	Press [I◀◀◀]/[I◀◀◀◀◀◀] successively twice or more.
Return to the beginning of current file	Press [I◀◀◀]/[I◀◀◀◀◀◀] once.
Start random playback (Playing music in a random order)	Press [RANDOM]. Each press switches the selection of iPod/iPhone play mode.
Start repeat playback (Playing music repeatedly)	Press [REAPET]. Each press switches the selection of iPod/iPhone play mode.

Playing a USB device

A USB flash memory or USB mass storage class compatible digital audio player can be connected to this unit to play music (audio files) in it.

- For the playable files, see "Playable audio files" (page 42).

Playback

1 Connect a USB device.

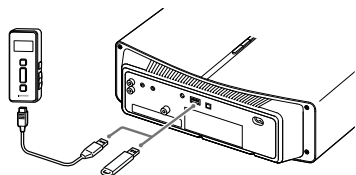

Connect the USB flash memory or the USB cable of the USB audio player to the USB connector of this unit (page 10). Also refer to the instruction for the connected device.

When you select USB source, "READING" is displayed and the input source is switched to USB. "USB" and "←" lights.

2 Start playback.

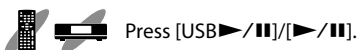

The folders and files are searched and playback is started with the file with the smallest file number.

- For the order of playback when there are multiple folders and/or audio files, see "Order of playback folders and audio files" (page 43).

- Playback does not start if there is no playable file in the USB device.
- When a digital HDD audio player is connected, the characteristics of the HDD system may cause the sound to be interrupted when playback is resumed after pause.

Folder play mode

The system can be set to a mode for playback per folder.

In this mode, the system plays only the selected folder and stops after all of its files have been played.

- Select the USB source and enter stop mode.

1 Select "□" (folder play mode).



Each press switches the playback mode.

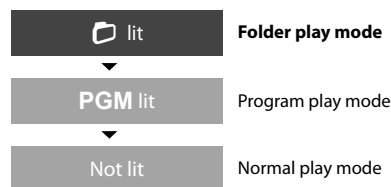

Display when the folder play mode is selected.



2 Select a folder and play it.



Display when folder 5 is selected.



When a folder is selected, "FOLDER" is displayed and the selected folder starts to play automatically.

■ To cancel the folder play mode...

Stop playback and press [P.MODE] to select the normal play mode.

Button operations during playback/stop

To	Operation
Switch the display information	Press [DISPLY] during playback or pause. Each press switches the displayed information (page 40).
Stop	Press [■] during playback.
Pause	Press [USB▶/]/[▶/] during playback. Press again to resume playback.
Select a file	Press the [Numeric] button(s). File number selection methods: 7th file → Press [7]. 12th file → Press [+10], then [2]. 103rd file → Press [+100], then [3].
Select a folder and/or file	To select a folder: Press [▲]/[▼]. To select a file: Press [I◀◀]/[▶▶I].
Fast forward/fast backward	Press and hold [I◀◀]/[▶▶I]/[I◀◀◀]/[▶▶▶I] during playback.
Skip a file	Press [▶▶I]/[▶▶▶I].
Return to previous file	Press [I◀◀]/[I◀◀◀] successively twice or more.
Return to the beginning of current file	Press [I◀◀]/[I◀◀◀] once.
Start random playback (Playing music in a random order)	Press [RANDOM]. Each press switches the selection. <div style="display: flex; align-items: center;"> <div style="margin-right: 10px;"> lit </div> <div style="margin-right: 10px;">▶</div> <div style="margin-right: 10px;"> Not lit </div> </div> Random playback is set. Random playback is cancelled. <ul style="list-style-type: none"> When [REPEAT] is pressed in the middle of random playback, random playback in a different order of audio files will start after the current random playback has completed. It is not possible to skip to already played music during random playback.
Start repeat playback (Playing music repeatedly)	Press [REPEAT]. Each press switches the selection. <div style="display: flex; align-items: center;"> <div style="margin-right: 10px;"> lit </div> <div style="margin-right: 10px;">▶</div> <div style="margin-right: 10px;"> lit </div> <div style="margin-right: 10px;">▶</div> <div> Not lit </div> </div> Repeat playback of a single audio file. Repeat playback of all audio files. Repeat playback is cancelled.

Playing a USB device

Program playback

Audio files can be played in the order programmed by the user.

- Select the USB source and enter stop mode.

1 Select "PGM" (program play mode).



Each press switches the playback mode.

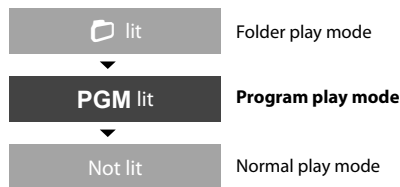

2 Select a file.

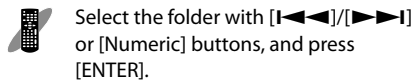

Select an audio file with [I<<<]/[>>>I] or [Numeric] buttons, and press [ENTER].

Display when file 10 in folder 003 is programmed as the 1st file in the program.



If you committed a mistake in selection, press [CLEAR] on the remote control unit before pressing [ENTER] and restart selection.

- Up to 32 files can be programmed.

3 Start playback.

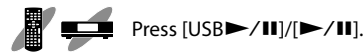

■ To clear a file from the program...

Stop playback and press [CLEAR] on the remote control unit. Each press clears the last track in the current program.

■ To add a file to the program after programming...

If playback is underway, stop it and perform steps 2 and after.

■ To cancel the program mode...

Stop playback and press [P.MODE] to select the normal play mode. The program is cleared at this time.

- The program is cleared when the system is turned OFF or the USB device used in programming is disconnected.

Playing an external component

An external component can be connected to AUX IN/DIGITAL IN of this unit and played back.

Playing an external component

1 Connect an external component.

Connect an external component to the [AUX IN] or [DIGITAL IN] connector on the rear of this unit (page 11).

- Also read the instruction manual for the connected auxiliary component.
- Be sure to turn both this system and the component OFF before connecting them.

2 Select the "AUX" or "D-IN" input.

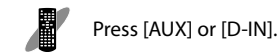

Display when the AUX input is selected.



Display when the DIGITAL IN input is selected.



Sampling frequency

- When DIGITAL IN is selected, the sampling frequency of the input signal is displayed. This unit can play the PCM (32 kHz/44.1 kHz/48 kHz) signals.

3 Start playing the connected external component.

- If the input level from the external component seems to be higher or lower than other input sources when this unit is set at the same volume level, adjust the input level as described in "Adjusting the input level" (page 27).

Adjusting the input level (INPUT LEVEL)

If the audio level of the connected external component is lower or higher than the level at the same volume control position of other audio sources, the input level of this system can be adjusted in the range between -3 and +5.

1 Select the "AUX" or "D.AUDIO" input source.

2 Enter the setup mode.



3 Select "INPUT LEVEL".



4 Adjust the input level.

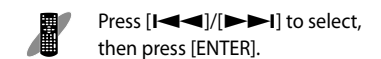

Display when the input level is adjusted to "+3".



- The input level adjustment is applied only to the audio source selected in step 1.

When the setting completes, the unit exits the setup mode automatically.

- Adjusting the input level also varies the input level of the signal from the external components connected to the [AUX IN] and [D.AUDIO IN] connectors.

Listening to Radio Broadcasting

A radio station can be selected and listened to.

Listening to Radio Broadcasting

1 Select the "TUNER" input.

 Press [TUNER].

 Press [INPUT SELECTOR].



2 Select a radio station.

Selecting a station preset in the memory (Preset call)

Select a radio station from the preset memory (No. 01 to 40).

 Press [I◀◀]/[▶▶I].

When preset No. 27 is selected.



- Holding the button depressed switches the preset numbers at intervals of about 0.5 second.
- The preset number can also be entered directly.
 Press the [Numeric] button(s) to select.
To select preset No. 27 → Press [+10] twice and [7] once.

Selecting a station that is not preset in memory (Auto tuning/Manual tuning)

1 Select the tuning mode.

 Press [I◀◀]/[▶▶I].

Each press switches the tuning mode alternately.

AUTO lit
Auto tuning
Auto reception is possible when the radio wave condition is favorable.

AUTO not lit
Manual tuning
When the radio wave condition is poor, vary the tuning frequency manually.

When auto tuning is selected.



2 Select a station.

 Press [I◀◀]/[▶▶I].

- **Auto Tuning:**
Each press tunes into the next receivable station automatically.
- **Manual Tuning:**
Each press varies the frequency by 1 step. Hold the button continuously varies tuned frequencies at a high speed.

- No audio is output during either auto or manual tuning.
- Auto Tuning receives stations in stereo audio but Manual Tuning receives them in monaural audio. "TUNED" lights up when a station is tuned. "ST" lights up when stereo broadcasting is tuned.

Presetting stations automatically (AUTO MEMORY)

Radio stations can be preset automatically in preset channels.

- Stations cannot be preset if other audio source is selected.
- Up to 40 stations can be preset in the system.
- Select the TUNER.
- For use of the Radio data system function, stations must be memorized by AUTO MEMORY.

1 Enter the setup mode.

 Press [MODE].

2 Select "AUTO MEMORY".

 Press [I◀◀]/[▶▶I] to select, then press [ENTER].



"SEARCHING" blinks on the display and the receivable radio stations are preset automatically. When the AUTO MEMORY operation has completed, the unit enters the condition in which preset station 01 is tuned.



- A broadcast station that cannot be preset with AUTO MEMORY should be set with Manual preset (page 30).

Listening to Radio Broadcasting

Presetting stations manually (Manual Preset)

The station being tuned can be preset in memory by specifying the preset number. If a station is preset in a preset number in which another station has already been preset, the existing setting is overwritten and replaced with the new setting.

- Up to a total of 40 stations can be preset in memory.

1 Tune the radio station to be preset in memory.

Tune with auto tuning or manual tuning (page 28).

2 Enter the tuned station.

Press [ENTER].



3 Select the desired preset number (01 to 40).

Press [1<<<|/|>>>1].

When preset No. 35 is selected.



- The preset number can also be entered directly.
- Press the numeric button(s) to select. To select preset No. 35 → Press [+10] 3 times and [5] once.

4 Preset a radio station.

Press [ENTER].

The radio station is preset in memory.

- To preset other stations, repeat steps 1 to 4 for each of them.



- Even when a station is preset, it cannot be tuned if the radio wave condition is poor.

Radio Data System

This system is designed for Radio data system reception, it can extract the information from the broadcast signal for use with various functions such as automatic display of the station name.

- Select the TUNER.
- Preset Radio data system stations with the AUTO MEMORY function (page 29).
- Some functions may not be provided or be given different names depending on countries or areas.

PS (Program Service Name) Display

When an Radio data system broadcast is received, the station name is automatically displayed.



The "RDS" indicator lights up when an Radio data system broadcast (signal) is received.

■ To switch the displays...

Press [DISPLAY].

Each press switches the selection.

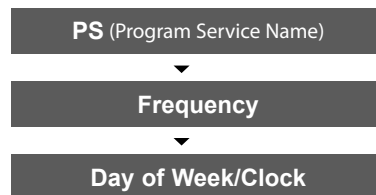

Searching for a desired program type (PTY search)

The tuner automatically searches for a station which is currently broadcasting a specified program type (genre).

1 Enter the PTY search mode.

Press [PTY].



When an Radio data system broadcast is received, the program type is shown on the display. If no PTY data is available, or if the station is not an Radio data system station, "None" is displayed.

2 Select the desired program type.

Press [1<<<|/|>>>1].

Select it while the "PTY" indicator is lit. Use program type table for your convenience.

Program type table

Program Type Name	Display
Pop Music	Pop M
Rock Music	Rock M
Easy Listening Music	Easy M
Light Classical	Light M
Serious Classical	Classics
Other Music	Other M
News	News
Current Affairs	Affairs
Information	Info
Sport	Sport
Education	Educate
Drama	Drama

Program Type Name	Display
Culture	Culture
Science	Science
Varied	Varied
Weather	Weather
Finance	Finance
Children's programs	Children
Social Affairs	Social
Religion	Religion
Phone In	Phone In
Travel	Travel
Leisure	Leisure
Jazz Music	Jazz
Country Music	Country
National Music	Nation M
Oldies Music	Oldies
Folk Music	Folk M
Documentary	Document

3 Start the search.

Press [PTY].



If a program of the desired type is found, that program is received and the program type name display changes to the station name display.

■ To cancel in the middle...

Press [PTY].



- If a program of the desired type cannot be found, "NO PROGRAM" blinks, then after several seconds the display returns to the original display.

Sound Adjustments

Enhancing the bass tone (D-BASS)

The level of the low frequency enhancement can be set as desired in the range from 0 (D-BASS OFF) to 10.

1 Select D-BASS.

 Press [D-BASS].



2 Adjust the enhancement level.

 Press [I<<<|/|>>>I].

The level can be adjusted in the increment/decrement of 1.

 **D-BASS 0** D-BASS is OFF.

 **D-BASS 5**

 **D-BASS 10** Low frequencies are enhanced.

"D-BASS" lights when D-BASS is set.

3 Enter the selection.

  Press [ENTER].

Adjusting the tone or playing surround audio (TONE)

The volume levels of low frequencies (BASS) and high frequencies (TREBLE) can be set independently in the ranges between -6 and +6. When DTS Surround Sensation is set, the music can be enjoyed in the 3D surround effect with high feeling of presence.

1 Select TONE.

 Press [SOUND].

Each press switches the tone mode alternately.

Adjust the low frequencies.



Adjust the high frequencies.



Select DTS Surround Sensation.



Cancels the setting mode.

2 Select the frequency range to be adjusted and adjust it to the optimum level. Alternatively, select DTS Surround Sensation for the surround effect.

■ When "BASS" or "TREBLE" is selected:

 Press [I<<<|/|>>>I].

The level can be adjusted in the increment/decrement of 1.

 **BASS +6** To increase

 **BASS 0**

 **BASS -6** To decrease

"TONE" lights when the BASS or TREBLE tone is set.

■ When "Surr Sens" is selected:

 Press [I<<<|/|>>>I].

Each press switches the DTS surround effect in the following order.

 **DTS OFF** Surround is OFF.

 **DTS ON : 1** Surround is ON.

 **DTS ON : 2** Surround effect is enhanced further.

"dts" lights when DTS Surround Sensation is set.

3 Enter the selection.

  Press [ENTER].

- It is not possible to adjust the tone (BASS/TREBLE), DTS Surround Sensation (dts) and D-BASS simultaneously.
- The DTS Surround Sensation (dts) effect is cancelled when headphones are connected. Disconnecting the headphones resumes the previous effect.

Resetting the adjusted sound to the original sound (FLAT)

The results of the D-BASS and TONE adjustments can be cancelled to flat levels so that the original sound is reproduced.

1 Select FLAT.

 Press [FLAT].

Each press switches FLAT/UNDO alternately. When FLAT is selected, the "D-BASS", "TONE" and "dts" settings are cancelled and their indicators extinguished.



- Pressing [FLAT] cancels the low frequency enhancement (D-BASS), tone adjustments (TONE) and DTS Surround Sensation effect (dts). Pressing it again returns the low frequency enhancement, tone adjustments and DTS Surround Sensation to the previous settings.

System Setup

Adjusting the Time (TIME ADJUST)

The day of the week and the time of the day of the system can be set.

1 Enter the setup mode.

 Press [MODE].

2 Select "TIME ADJUST".

 Press [◀◀]/[▶▶] to select, then press [ENTER].



3 Set the day of the week, hour and minute.

Adjust the day of the week, the hour, then the minute.

 Press [◀◀]/[▶▶] to select, then press [ENTER].



4 Enter the selection.

 Press [ENTER].

When the setting completes, the unit exits the setup mode automatically.

- To display time of day when the system is OFF (standby mode):

  Press [■].

The time of the day is displayed for 5 seconds.



- 💡 If the power cord is unplugged then plugged in or after a power failure, adjust the time of the day again.
- The clock operation involves a certain error. It is recommended to adjust the time of the day periodically.

Setting the Sleep Timer (SLEEP)

When the sleep timer (10 minutes up to 90 minutes) is set before or during listening to an input source, this unit stops playback when the set time has expired and switches OFF automatically.

1 Set the Sleep Timer.

 Press [SLEEP].

Each press switches the set time.

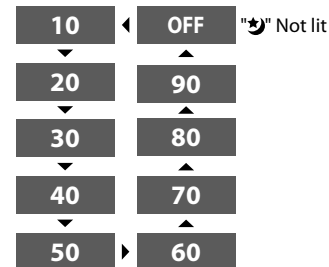

Display when the sleep timer is set to 30 min.



"🌙" lights when the sleep timer is set.

- To check the remaining period of the sleep timer after setting...

 Press [SLEEP].

The remaining sleep timer period is displayed for 5 seconds.



- When [SLEEP] is pressed now, the sleep timer can be set from the current remaining time.

- 💡 The sleep timer cannot be set when the system status is one of the following:
 - In standby mode
 - During power OFF processing
 - During clock/program timer setting

Setting the program timer (TIMER SET)

The program timer makes it possible to play radio broadcasting, a CD or a USB device on the specified time of the specified day(s) of the week.

Up to 2 timer programs can be set.

- Be sure to adjust the clock to the correct time. For the procedure, see "Adjusting the time (TIME ADJUST)" (page 34).
- When setting more than one timer program, reserve an interval of at least 1 minutes between the time zones of the programs.

1 Enter the setup mode.

Press [MODE].

2 Select "TIMER SET".

Press [I◀▶I]/[▶▶I] to select, then press [ENTER].



3 Select the program number.

Press [I◀▶I]/[▶▶I] to select, then press [ENTER].

PROG. 1 SET Program 1 is selected.

PROG. 2 SET Program 2 is selected.

Display when program 1 is selected.



4 Select and enter the program items.

Press [I◀▶I]/[▶▶I] to select, then press [ENTER].

ON/OFF Select timer ON/OFF.

EVERYDAY Set the day(s) of the week.

ON TIME Select the ON time.

OFF TIME Select the OFF time.

PLAY MODE Select the timer operation mode.

VOLUME Select the playback volume.

PLAY SOURCE Set the audio source.

For the setting items, see "Program item list" (page 37).

When the setting completes, "COMPLETE" is displayed and the unit exits the setup mode automatically.

Display when 2 programs 1 and 2 are set.



5 Turn the system OFF.

Press [POWER].

The [STANDBY/TIMER] indicator lights orange.

• If the power cord is unplugged then plugged in or after a power failure, adjust the time of the day again (page 34).

Program item list

Programming item	Summary	Selection options
ON/OFF	Select whether the timer is executed or canceled.	ON: Executes the timer operation. OFF: Cancels the timer operation.
Day of the week setting	Select the day of the week.	EVERYDAY
		SUNDAY
		MONDAY
		TUESDAY
		WEDNESDAY
		THURSDAY
		FRIDAY
		SATURDAY
		MON-FRI (Monday to Friday)
		TUE-SAT (Tuesday to Saturday)
		SAT-SUN (Saturday, Sunday)
ON TIME	Select the timer start time.	① Set the figure of "HOUR". Select with [I◀▶I]/[▶▶I] and press [ENTER]. ② Set the figure of "MINUTE". Select with [I◀▶I]/[▶▶I] and press [ENTER].
OFF TIME	Select the timer end time.	
PLAY MODE	When AI PLAY is set, the volume is increased gradually until the level set with VOLUME.	PLAY: AI PLAY is cancelled. (The playback begins at the level set with VOLUME.) AI PLAY: AI PLAY is executed.
VOLUME	Select the playback volume level.	This item can be set between 0 and 40 (MAX).
PLAY SOURCE	Select the input source to be played from TUNER (radio)/CD/iPod/USB/D-IN/AUX. When TUNER (radio) is selected, select the preset number of the desired preset station.	

■ To cancel (OFF) or re-set (ON) the timer...

Press [TIMER].

Each press switches the timer setting ON/OFF alternately.

1 lit Program 1 is ON.

2 lit Program 2 is ON.

12 lit Programs 1 and 2 are ON.

Not lit Timer is OFF.

• Be sure to set the timer with this unit ON.

Setting the display saver (DISP. SAVER)

When this unit has not been controlled for a certain period of time, the display scrolls to prevent burns and brightness irregularities from being produced on the display panel.

1 Enter the setup mode.

 Press [MODE].

2 Select "DISP. SAVER".

 Press [I◀◀]/[▶▶I] to select, then press [ENTER].



3 Set Display Saver.

 Press [I◀◀]/[▶▶I] to select, then press [ENTER].

D. SAVER ON Display Saver is ON.

D. SAVER OFF Display Saver is OFF.

When the setting completes, the unit exits the setup mode automatically.



When the input source is CD/USB, Display Saver is activated when the unit has not been controlled for 10 minutes after the end of the last playback. With other inputs, Display Saver is activated when the unit has not been controlled for 10 minutes after a button is pressed.

Setting Auto Power Save (A.P.S. SET)

A.P.S. stands for Auto Power Save, which is the function that switches this unit OFF when it has not been controlled for more than 30 minutes while its power is ON and the CD and other inputs are in stop mode.

1 Enter the setup mode.

 Press [MODE].

2 Select "A.P.S. SET".

 Press [I◀◀]/[▶▶I] to select, then press [ENTER].



3 Set the A.P.S. mode to ON/OFF.

 Press [I◀◀]/[▶▶I] to select, then press [ENTER].

A.P.S. ON A.P.S. mode is ON.

A.P.S. OFF A.P.S. mode is OFF.

When the setting completes, the unit exits the setup mode automatically.

"A.P.S." lights when A.P.S. is set to ON.

■ When the A.P.S. mode is ON...

A.P.S. is activated when this unit is in either condition below.

- When the input source is TUNER, AUX, D.AUDIO, iPod or DIGITAL IN, the volume level is 0 and no button has been pressed for 30 minutes.
- When the input source is CD or USB, the CD player or USB device is in stop mode and no button has been pressed for 30 minutes.

Adjusting the recording output level (Rec Out LEVEL)

If the audio recorded on the component connected to the [REC OUT] connector is distorted or too low, adjust the recording output level.

1 Select the input source to be output at the recording output.

2 Enter the setup mode.

 Press [MODE].

3 Select "RecOut LEVEL".

 Press [I◀◀]/[▶▶I] to select, then press [ENTER].



4 Adjust the recording output level.

 Press [I◀◀]/[▶▶I] to select, then press [ENTER].

The recording level can be adjusted as desired in the range between -2 and +2.

Display when the recording output level is "+2".



When the setting completes, the unit exits the setup mode automatically.

Setting the brightness of the display (DIMMER)

The brightness of the display can be set as desired.

1 Sets the display brightness.

 Press [DIMMER].

Each press switches the dimmer mode alternately.

Switching the Display Information



Press [DISPLAY] or [TIME DISPLAY].

The displayed information varies as shown below according to the operating status of and selected audio source of the system.

Audio source	[DISPLAY]	[TIME DISPLAY]
CD (commercially available CD) CD-DA format	Playback	Stop
	File title*	Album name*
	Track No./ Track play time	Track count/ Disc play time
	Day of Week/Clock	Day of Week/Clock
Audio files USB	File No./File play time	Folder/track count
	File name	File name
	Folder name	Folder name
	Music title	Day of Week/Clock
	Artist Name	Elapsed time of played music
	Album Name	
	Day of Week/Clock	
iPod/ iPhone D.AUDIO/ AUX DIGITAL IN	Day of Week/Clock	
TUNER (radio)	With station name	Without station name
	Station name	Receiving frequency
	Receiving frequency	NO PS
	Day of Week/Clock	Day of Week/Clock

The maximum displayable time is 999 min. 59 sec.

*The track and album titles are displayed when the CD-TEXT data is available.

Additional Information

Media Usable With This System

Medium	Note
USB	USB flash memory
	USB mass storage class compatible digital audio player
CD	Commercially available CD
	CD-R/CD-RW recording the CD-DA format data
	CD-ROM/CD-R/CD-RW recording MP3/WMA/AAC data

- Do not connect a component other than a USB flash memory or a USB mass storage class compatible digital audio player to the [USB] terminal. Kenwood will not assume any liabilities for the malfunction, damage or loss of data that may result from connection of other kind of component.

- Discs that do not comply with the CD standards, such as the copy controlled CD may sometimes be unable to be played.
- Finalizing is required after disc writing.
- The CD-ROM, CD-R and CD-RW may sometimes unable to be played with this system depending on the equipment use for recording, the recording conditions and the type of disc.

Caution for Disc Writing

- A disc recorded with the packet write method or UDF (Universal Disc Format) cannot be played back.
- Be sure to close the session or finalize the disc after writing. A disc that has not been closed or finalized may be unable to be played properly.
- The written folder and file names may not be displayed properly depending on the specifications of the software used in writing.
- When a multi session disc or a disc containing a large number of folders is played, the time before playback starts may be longer than ordinary discs.
- If both audio files and CD files (CD-DA format) are written on a single disc, it may be unable to be played properly.
- Before writing audio files in a disc, make sure that the PC used in writing can play the files properly. After writing, also confirm that the written files can be played properly.
- Be sure to attach the correct extension (mp3, wma or m4a) to the filename of each audio file. A file without the extension cannot be played. Also do not attach an audio file extension (mp3, wma or m4a) to a non audio file. For the file extensions, see "Playable audio files" (page 42).

Additional Information

Playable audio files

This unit can play the CD-ROM, CD-R and CD-RW discs and the USB devices recording the following types of audio files.

MP3 file

File format: MPEG 1 Audio Layer 3/MPEG 2 Audio Layer 3/
MPEG 2 Audio Layer 3 Lower sampling rate (MPEG2.5)

File extension: .mp3

Sampling frequency:

MPEG 1 Audio Layer 3: 32 kHz/ 44.1 kHz/ 48 kHz

MPEG 2 Audio Layer 3: 16 kHz/ 22.05 kHz/ 24 kHz

MPEG 2.5: 8 kHz/ 11.025 kHz/ 12 kHz

Bit rate:

MPEG 1 Audio Layer 3: 32 kbps ~ 320 kbps

MPEG 2 Audio Layer 3: 8 kbps ~ 160 kbps

MPEG 2.5: 8 kbps ~ 160 kbps

WMA file

File format:

Windows Media™ Audio compliant

File extension: .wma

Sampling frequency: 32 kHz/ 44.1 kHz/ 48 kHz

Bit rate: 48 kbps ~ 192 kbps

- Files created with the following functions provided Windows Media™ Player 9 or after cannot be played back:
 - WMA Professional
 - WMA Lossless
 - WMA Voice

AAC file

File format: MPEG-4 AAC (created using iTunes™ 4.1 to 9.2)

File format: .m4a

Sampling frequency: 16 kHz/ 22.05 kHz/ 24 kHz/ 32 kHz/
44.1 kHz/ 48 kHz

Bit rate: 32 kbps ~ 320 kbps

- Files created using the Apple lossless encoder cannot be played back.

Disc formats

ISO 9660 Level 1

ISO 9660 Level 2

Joliet

Romeo

USB compatible file systems

FAT16

FAT32

File number limits

Maximum number of folders: 255

Maximum number of files: 999

Maximum number of displayable characters

Folder name: 64 characters

Filename: 64 characters (including extension)

Tag display (Title/Album/Artist)

ID3 v1.0/ 1.1: 30 characters

ID3 v2.2/ 2.3/ 2.4: 100 characters

- The non displayable character is displayed as "***".

Other cautions

- Even audio files compliant to the above standard may be unable to be played depending on the characteristics and recording conditions of the disc.
- Playback may sometimes be impossible depending on the specifications and setup of the software used in encoding.
- Files with DRM (Digital Rights Management) cannot be played back.
- Audio files encoded with VBR (Variable Bit Rate) may include bit rates exceeding the compatible bit rate range of this unit. Such audio files containing incompatible bit rates cannot be played back.

Order of playback of folders and audio files

Audio files are played beginning with those located in the Root directory.

The following diagram shows how this system selects the stored audio files.

Folder configuration example

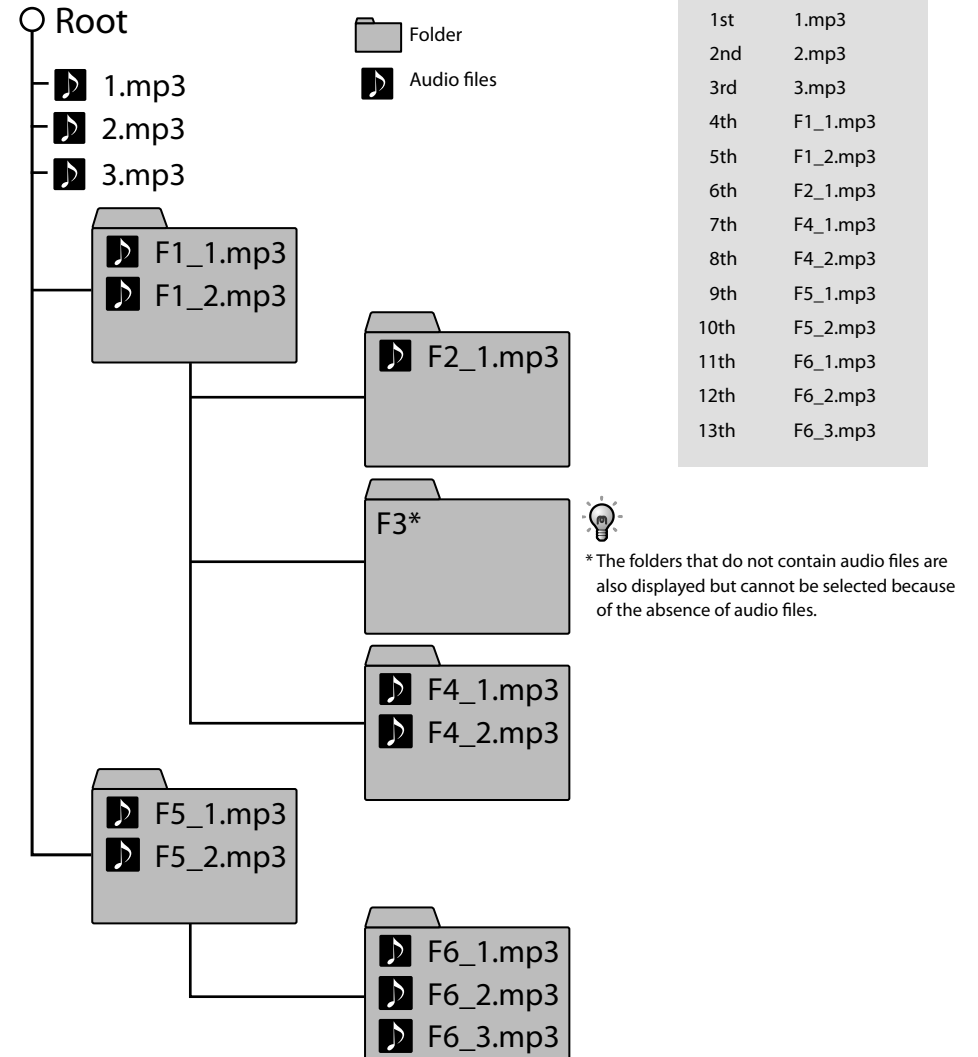

Additional Information

Handling of CD

Handling precautions

- Hold a CD taking care not to touch the played surface.
- Do not use any disc accessory (stabilizer, protective sheet, protection ring, etc.).
- Do not use a CD if the sticker or label on it is peeled off or paste is projected from below a sticker or label.
- Do not stick a sheet of paper, sticker or label on a CD.
- Do not write letters on a CD using a pencil or ballpoint pen.

Discs playable on the system

- The audio part of a CD (12 cm), CD-ROM, CD-R, CD-RW and CD-EXTRA can be played back.

Notes on CD-ROM/CD-R/CD-RW discs

- If a CD-ROM, CD-R or CD-RW with a printable label is used, the label surface may stick to the internal mechanism, making it impossible to eject the disc. To prevent malfunction of the system, do not use such a disc.

Cautions on CD discs

Always use a disc carrying the  marking.

A disc without this marking may be unable to be played back correctly.

- The disc rotates at a high speed during playback. Never use a cracked, chipped or greatly warped disc. Otherwise, damage or malfunction of the player may result.
- Also, do not use a disc with a non circular shape as this may result in malfunction.
- The 8 cm CD adapter cannot be used.

CD storage

- When the main unit is not to be used for a long period, take out the CD and store in the case.

When a CD gets dirty

- When a disc is stained with dirt or fingerprints, wipe the disc in the radial direction with a soft cloth, etc.
- Do not use an analog disk cleaner, lacquer thinner, benzine or alcohol.

Handling of D.AUDIO

Handling precautions

- Be sure to read the instruction manual provided with your Kenwood digital audio player.
- The Kenwood digital audio player is not provided with this system.
- The saved data may be lost depending on the operating situations of the Kenwood digital audio player. Kenwood will not assume any liabilities for the damage incurred due to loss of saved data.

Usable D.AUDIO

- To control a Kenwood digital audio player from this unit or the remote control unit, it is required to purchase the optional Kenwood digital audio player connection cable.

Usable Kenwood digital audio player models

HDD audio player	Memory audio player/recorder
HD20GA7	MGR-E8/MGR-A7 M2GD55/M1GD55 M1GC7/M2GC7

As of Sep. 2010.

Handling of iPod

Handling precautions

- Be sure to read the instruction manuals provided with your iPod/iPhone.
- The iPod/iPhone is not provided with this system.
- The saved data may be lost depending on the operating situations of the iPod/iPhone. Kenwood will not assume any liabilities for the damage incurred due to loss of saved data.

Usable iPod/iPhone models

The following iPod/iPhone models can be connected to this unit (as of Sep 2010).

Made for

- iPod nano (6th generation)
- iPod nano (5th generation)
- iPod nano (4th generation)
- iPod nano (3rd generation)
- iPod nano (2nd generation)
- iPod classic
- iPod touch (4th generation)
- iPod touch (3rd generation)
- iPod touch (2nd generation)
- iPod touch (1st generation)
- iPhone 4
- iPhone 3GS
- iPhone 3G

Handling of USB device

Handling precautions

- Be sure to read the instruction manuals provided with each USB device.
- The USB device is not provided with this system.
- The [USB] connector on the rear of this unit is USB2.0 (Full speed) compatible.
- It is not permitted to connect a USB device through a USB hub.
- The data saved in the USB device may be lost depending on the usage conditions. Kenwood will not assume any liabilities for the damage incurred due to loss of saved data.

Usable USB devices

The following restrictions are applicable to the type and operating method of the USB device.

- The USB device should be USB mass storage class compatible. For whether each USB device is compatible with the USB mass storage class, consult its dealer.
- The maximum current drain should be no more than "500 mA".

If a USB device other than specified above is used, the music files may be unable to be played correctly. Also, note that even a USB device complying with the above specifications may be unable to play certain music files depending on the type or condition of the music files.

Caution for Transport or Movement

Before transporting or moving the system, prepare it as described below.

- 1 Disconnect the external components including the USB device, and also take out the disc.
- 2 Press [CD ▶/||] and confirm that "NO DISC" is displayed.
- 3 Wait a while, and then turn the system OFF.
- 4 If any other external component is connected, make sure that it is turned OFF before disconnecting the connection cable.

Memory Backup

Even when the power plug is unplugged from the mains outlet, the setups of the unit are retained for about a day.

The backed up setups are as follows.

Sound and system setups

- Input source selection
- Volume setting
- Input level setting
- D-BASS and TONE settings
- TIMER SET setting
- DIMMER setting
- DISP. SAVER setting
- A.P.S. setting
- Rec Out LEVEL setting

Tuner setups

- Preset stations
- Tuning mode (Auto/manual tuning)
- Receiving frequency

Troubleshooting

A trouble with the system does not always mean the failure. Before calling for service, check the following table according to the symptom of trouble.

Amplifier/Speaker Section

Symptom	Remedy	See page
No sound output.	• Reconnect the cords properly.	9~11
	• Increase the volume level.	16
	• Cancel muting.	16
	• If headphones are plugged in, unplug them.	11
The [STANDBY/TIMER] flashes red and no sound is output.	• An internal fault may be produced. Turn the system OFF, unplug the power cord and call for service.	—
No sound from headphones.	• Check if headphone plug is inserted properly.	11
	• Increase the volume level.	16
	• Cancel muting.	16
The time of the day is not displayed.	• Set the time of the day.	34
Turn the system OFF automatically.	• Set the A.P.S. mode to ON.	38
Timer cannot be activated.	• Set the time of the day ([STANDBY/TIMER] indicator is flashing in orange).	34
	• Set the On time and Off timer of program timer.	36

Tuner Section

Symptom	Remedy	See page
Radio stations cannot be tuned.	• Connect the antenna(s).	9
	• Select the correct tuning mode.	28
	• Tune into the frequency of the desired station.	28
Noise interferes with reception.	• Install the outdoor antenna away from the road.	—
	• Turn OFF the electric appliances installed near this system.	
	• Install the system away from a TV set.	
Preset stations cannot be called.	• Preset radio stations with AUTO MEMORY again.	29
	• Preset stations with receivable frequencies manually.	30

USB/iPod/iPhone Section

Symptom	Remedy	See page
Sound is not output even when a USB flash memory or USB mass storage class compatible audio player/iPod and iPhone is connected.	<ul style="list-style-type: none"> • Insert the iPod/iPhone properly. • Insert the USB flash memory properly. • Connect the USB cable properly. • Check if the USB mass storage class compatible digital audio player is turned ON. 	10

CD Section

Symptom	Remedy	See page
Loaded CD cannot be played back.	• Place the CD properly with the label side up.	17
	• Clean the disc.	44
	• Wait until the condensation on the disc surface evaporates.	44
CD audio is not output.	• Press [CD▶/III].	17
	• Clean the disc.	44
CD sound skips.	• Playback is impossible if the audio file is destroyed.	42
	• Check if the audio file is playable with this system.	
An audio file cannot be played.	• Playback is impossible if the audio file is destroyed.	42
	• Check if the audio file is playable with this system.	
Playback takes time before starting.	• The time until playback may become long if there are large number of folders and/or files.	—
The TAG information is displayed improperly.	• Confirm the TAG information that can be displayed on this unit.	42

Component connected to D.AUDIO IN connector

Symptom	Remedy	See page
Kenwood digital audio player cannot be controlled from the main unit or remote control unit.	• Connect it using the special connection cable (optional).	11
	• Check if a compatible model is connected.	44

Remote Control Unit

Symptom	Remedy	See page
Remote control is unavailable.	• Replace the batteries with new ones.	7
	• Use the remote control unit within the controllable distance.	15

Resetting the system

Symptom	Check Points & Remedy
The system malfunctions (resulting in inoperability of the system, erroneous display, etc.).	<p>The system may malfunction due to unplugged and plugging of a cable while the system is ON or to an extraneous cause. In this case, reset the system with the following steps. Resetting the microcomputer results in erasing the setups of the system and returns it to the factory shipped condition.</p> <ol style="list-style-type: none"> 1 Unplug the power plug from the mains outlet. 2 While pressing and holding [⏻] on the main unit, unplug the power cord and plug it again. <p>"INITIALIZE" is displayed. This unit is reset.</p>
	INITIALIZE

Message List

Displayed Message	Description
CAN'T PLAY	An attempt was made to play an audio file that cannot be played with this unit.
CHECK DISC	<ul style="list-style-type: none"> The TOC*¹ information cannot be read. The disc is loaded improperly.
CONNECT ERR	iPod or iPhone is not connected.
D-IN ----	The sampling frequency of the input signal is other than 32k/ 44.1k/ 48k Hz.
D-IN NonPCM	A non PCM signal is input to the DIGITAL IN connector.
D-IN UNLOCK	<ul style="list-style-type: none"> No digital component is connected to the DIGITAL IN connector. The digital component connected to the DIGITAL IN connector is not switched ON.
NO DISC	No CD disc is loaded.
NO iPod	No iPod/iPhone is connected.
NO USB	No USB device is connected.
NOT FOUND	There is no file that can be read by this system.
NOT SUPPORT	Cannot be used with this unit is connected.
PGM FULL	An attempt was made to program the 33rd audio file. (Programming is possible up to 32 audio files.)
PROTECTED	An attempt was made to play a DRM (Digital Rights Management) protected audio file.

*1: The CD contains information called TOC (Table Of Contents) in addition to audio signals. Like the table of contents of a book, the TOC includes non rewritable information among the information on the disc such as the number of tracks, playing time and other character information.

Glossary

Term	Description
AAC	AAC stands for "Advanced Audio Coding", which is an audio compression method use with the video compression of digital broadcasting, etc.
CD-DA	Stands for "Compact Disc – Digital Audio". The CD-DA is usually called "CD".
CD-TEXT	Music CD in which the character information such as the disc titles, artist names, track titles, etc. is recorded.
DTS Surround Sensation	This is an audio reproduce system developed by DTS, Inc., and is capable of reproducing high quality 3D surround audio using two speakers. It makes it possible to enjoy feeling of presence of 3D surround from a 2-channel stereo input source.
MP3	An audio compression method developed by Fraunhofer IIS, Germany. It achieves a high compression rate by thinning out the data of the sound that is less audible to human ears. It can compress music CD data into about 1/11 (128 kbps) while maintaining similar audio quality.
PCM	PCM stands for "Pulse Code Modulation", which is a system for converting analog audio signals into digital data. The CD (CD-DA) utilises the PCM system with a sampling frequency of 44.1 kHz.
USB	Standard for interfacing between the PC and peripheral devices. This system is compatible with USB 1.1 and 2.0.
USB hub	Adapter for connecting more than one USB device simultaneously.
USB mass storage class	Standard for controlling a USB device from a PC. Also, refers to the action that a PC recognizes a USB device connected to it as an external storage device.
VBR (Variable Bit Rate)	Technology for assigning the bits by varying their quantity according to the amount of music information.
WMA	Stands for "Windows Media™ Audio", which is an audio compressed encoding system developed by Microsoft Corporation.
Sampling frequency	Number of times analog signal is converted into digital signal per second. It is 44.1 kHz with music CD. In general, higher sampling frequencies offer higher audio quality.
TAG information	Information written in audio file, including the title name, artist name, album name and genre.
Bit rate	Figure expressing the amount of information per second. A higher bit rates offer higher audio quality.

Care and Storage

Care and storage of main unit

Do not place in the following locations

- Place exposed to direct sunlight.
- Place subjected to excessive humidity or dirt.
- Place exposed to direct heat from heating equipment.

Be careful against condensation

When the difference in temperatures between the main unit and the environmental air is large, dew may be condensed inside the main unit and may cause malfunction of the main unit. If this happens, leave the main unit for a few hours until its internal mechanisms are dried up.

Take special care against condensation when the main unit is moved between places with a large temperature difference or into a room with high humidity.

When the unit becomes dirty

When the front panel or case gets dirty, wipe with a soft dry cloth. Do not use lacquer thinner, benzene, alcohol or contact revitalizer for these chemicals will cause discoloration or deformation.

• "Made for iPod," and "Made for iPhone" mean that an electronic accessory has been designed to connect specifically to iPod, or iPhone, respectively, and has been certified by the developer to meet Apple performance standards. Apple is not responsible for the operation of this device or its compliance with safety and regulatory standards. Please note that the use of this accessory with iPod, or iPhone may affect wireless performance.

• iPhone, iPod, iPod classic, iPod nano, and iPod touch are trademarks of Apple Inc., registered in the U.S. and other countries.

Manufactured under license from DTS Licensing Limited. DTS and the Symbol are registered trademarks, & DTS Surround Sensation and the DTS logos are trademark of DTS, Inc. Product includes software. © DTS, Inc. All Rights Reserved.

Windows Media is a registered trademark or trademark of Microsoft Corporation in the United States and other countries.

Other system names and product names are generally trademarks or registered trademarks of their developers. However, note that the text in this manual does not use the TM and ® markings to them.

Specifications

[Amplifier section]

Rated power	
Output power	20 W + 20 W RMS (1 kHz, 10 W, 8 Ω)
Total harmonic distortion	0.05 % (1kHz, 1W, 8 Ω, 30 kHz LPF)
Frequency response	10 Hz ~ 20 kHz
Tone control characteristics	
BASS	±6 dB (100 Hz)
TREBLE	±6 dB (10 kHz)
Input terminals (Sensitivity/impedance)	
D.AUDIO/AUX (INPUT LEVEL 0)	300 mV / 27 kΩ
Output terminals (Level/impedance)	
Recording output (REC OUT LEVEL 0)	900 mV / 10 kΩ

[Tuner section]

FM tuner	
Tuning frequency range	87.50 MHz ~ 108.00 MHz
Antenna impedance	75 Ω unbalanced

[CD section]

Read method	Non-contact optical readout (laser diode)
D/A Converter	1 bit
Oversampling	8 fs (352.8 kHz)

[USB section]

Compatible USB devices	USB mass storage class devices
Interface	USB 2.0 (Full speed), USB 1.1 compatible
Compatible file system	FAT 16/32
Maximum supply current	500 mA

[Digital section]

Compatible sampling frequencies	32k/44.1k/48k Hz
Input connectors (Sensitivity/Wavelength)	Optical (-15 dbm to -24 dbm/660 nm ±30 nm)

[Speakers section]

Enclosure	Bass reflex system
Speakers	80 mm cone type
Impedance	8 Ω
Maximum input	30 W

[General section]

Power consumption	25 W
Power consumption in standby mode	0.5 W or less
Dimensions (Max.)	Width 390 mm Height 119.5 mm Depth 277.5 mm
Weight	5.8 kg (net)

- Design and specifications are subject to change without notice.
- The system may be unable to manifest the full performance in an extremely cold place (under the water freezing temperature).



KENWOOD

For your records

Record the serial number, found on the back of the unit, in the spaces designated on the warranty card, and in the space provided below. Refer to the model and serial numbers whenever you call upon your dealer for information or service on this product.

Model _____ Serial Number _____